

EXTERNAL BELT SCRAPER

MAIN SCRAPER MODEL : CMS-200

CARESS BELT CONVEYORS
Clean with CONCARE Belt Scrapers.

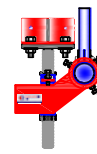

Specifications

Multi Blades Segmented Type. Self Adjusting Positive Element Pre Loaded Sprung Back Torsion Arm mechanism at both ends for inbuilt pressure and constant contact & Automatic Adjustments against Wear along with Wear Indicator. All Hardware's are Stainless Steel.

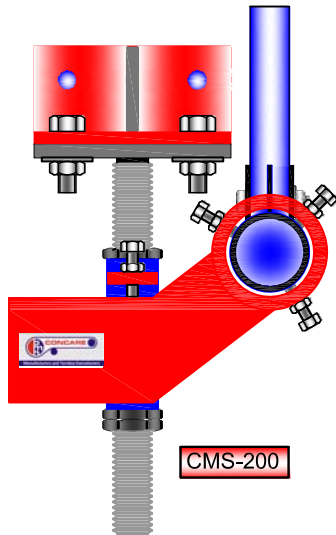

Increased conveyor operation efficiency.

Nil material wastages
Results in good environment.

Longer belt life.

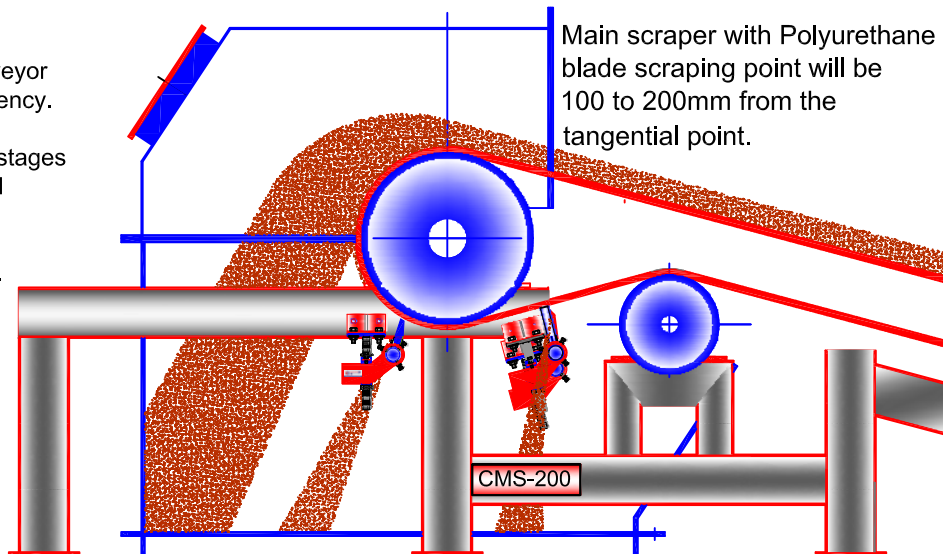

Main scraper with Polyurethane blade scraping point will be 100 to 200mm from the tangential point.

PU blades flex in the direction of belt travel maintaining effective constant pressure for better cleaning. Recommended for moisturized and sticky materials. Suitable for high capacity, high speed belts with larger head pulleys. Cuts sticky material to material adhesion.

Belt width	Assembly Length	Cleaning width
500mm	1500mm	400mm
600mm	1600mm	600mm
650mm	1700mm	600mm
800mm	1900mm	800mm

Belt width	Assembly Length	Cleaning width
1000mm	2100mm	1000mm
1200mm	2400mm	1200mm
1400mm	2600mm	1400mm
1600mm	2900mm	1600mm

Belt width	Assembly Length	Cleaning width
1800mm	3100mm	1800mm
2000mm	3300mm	2000mm
2200mm	3500mm	2200mm
2400mm	3700mm	2400mm

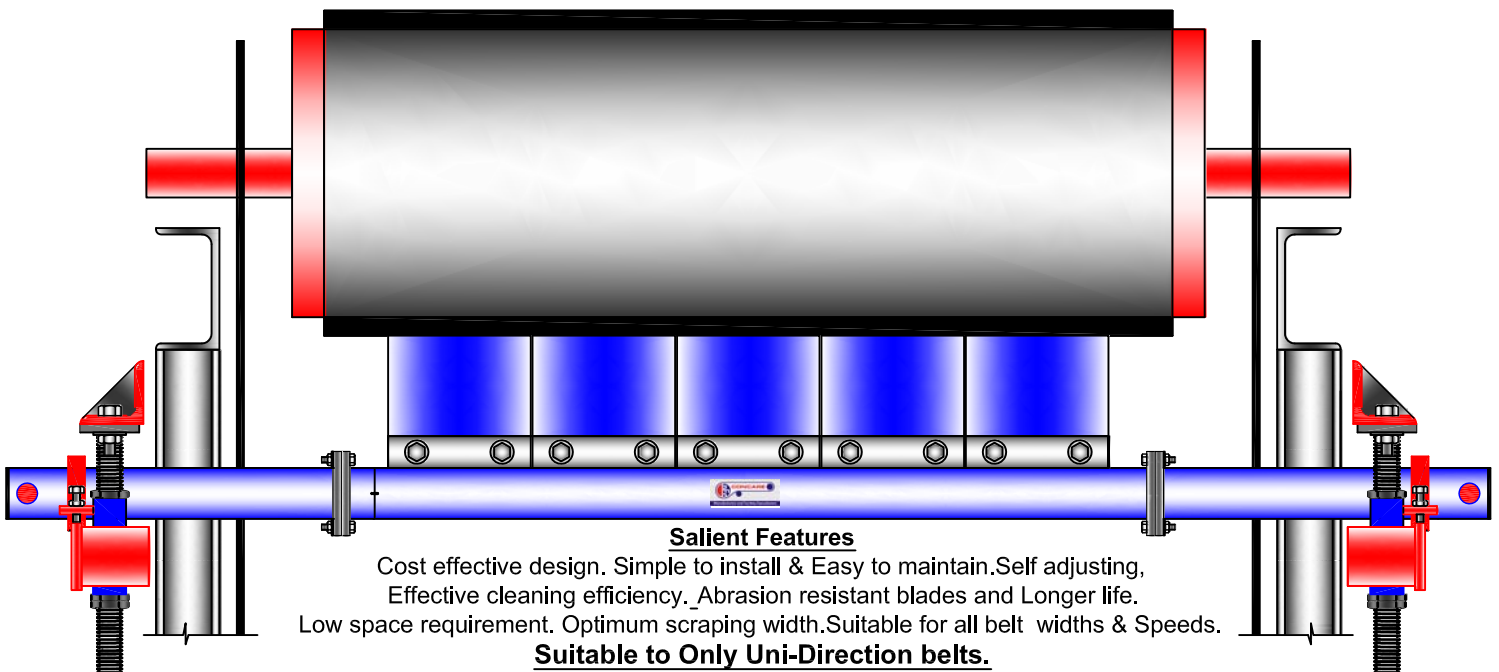

Salient Features

Cost effective design. Simple to install & Easy to maintain. Self adjusting, Effective cleaning efficiency. Abrasion resistant blades and Longer life. Low space requirement. Optimum scraping width. Suitable for all belt widths & Speeds.

Suitable to Only Uni-Direction belts.

Head Office & Works

Caress Belt Conveyors by **BMH CONCARE TECHNOLOGY INC.**

Plot no. 56, Sector-1, Service Industrial Area, Nerul (East), Navi Mumbai - 400 706 India.

Phone :- 022 27702626 / 3258 4616 / 09324297633 / 09324383067

Fax :- 022 27702625. E-Mail :- bmhsales@bmhconcare.com / bmhprojects@bmhconcare.com

**A REVOLUTION IN
ENVIRONMENTAL ENGINEERING**

BMH / CMS-200/006